

“4X4 NEZ CHAMPIONSHIP 2021”

Regulations

Chapter 1. General rules.

- 1.1. LAF Trophy-raid committee, LASF 4x4 committee, EAU 4x4 Off-road committee – Estonia. ”4x4 NEZ CHAMPIONSHIP” series, hereinafter called NEZ CHAMPIONSHIP.
- 1.2. Normative documentation of the NEZ CHAMPIONSHIP:
 - NEZ CHAMPIONSHIP Official regulations - Organizing regulations of Trophy raid NEZ event
- 1.3. NEZ CHAMPIONSHIP series will take place in:
 1. Lithuania 23-25.04 2021–Kupiskis trophy 2021
 2. Latvia 23-25.07.2021–Signals EM trophy 2021
 3. Estonia 15-17.102021 Estonia, Sirgala [MudEst](#) 2021
- 1.4. Series regulations
 - 1.4.1 It is mandatory to print on the front cover of event regulations:
 - Championship logo
 - Organizers logo - Type, name, status and date of the race
 - 1.4.2 Regulations of the race are developed by the Organizer based on standard regulations.
 - 1.4.3 All additions to the standard regulations are to be marked in *Italic type* in regulations. All specific rules or technical requirements that contradict standard regulations are to be marked in *Italic type* in the regulations of the current race, and must be agreed by NEZ Trophy raid Working group.
- 1.5. Officials of the race:
 - Sports commissar
 - International commissar
 - Technical commissar
 - Organizer of the race
- 1.6. Regulations must be published at least one month before the entry submission time limit ends, on leading 4x4 websites of Latvia, Lithuania and Estonia.
- 1.7. Once the entry submission has begun no changes are allowed to the regulations, except changing the officials of the race, changes that are accepted by all those who have submitted the entries and changes made by

Technical commissar due to force majeure conditions or due to the safety issues.

- 1.8. The sports commissar must be presented with the safety plan before the beginning of the race.
- 1.9. To include a traditional race in to the calendar of the next year's NEZ CHAMPIONSHIP series an application must be submitted (trofi@trofi.lv) till first of September 2021.

Chapter 2. Participants

- 2.1. In 2021 NEZ CHAMPIONSHIP teams collect points during all the series of the NEZ CHAMPIONSHIP.
- 2.2. Entry submission starts at the moment when the regulations are published and ends 3 days before the beginning of the race.
 - 2.2.1 All participants receive points during the 2021 NEZ CHAMPIONSHIP. A team consists of 2-3 participants (2-4 for TR1 category), from whom at least one must be a driver. All the team members who have driver's licenses have the right to drive the car during the race.
 - 2.2.2 Participants have to present the Trophy raid license given to him by National federation, to be able to participate in the NEZ CHAMPIONSHIP.
- 2.3. Vehicle categories of the NEZ CHAMPIONSHIP:
 - First category – automobiles that correspond to TR1 technical specifications
 - Second category – automobiles that correspond to TR2 technical specifications
 - Third category – automobiles that correspond to TR3 technical specifications
 - Fourth category – automobiles that correspond to OPEN technical specifications.

Chapter 3. Automobile

Gross vehicle weight must not exceed 3,5 tons. The vehicles must be in compliance with international convention on road traffic safety.

- 3.1. Preparation of the automobile should be in compliance with technical specifications of the corresponding category of the vehicle.
- 3.2. Automobiles are divided in following categories:
 - TR1:** these are conventional cars with very few changes that correspond to TR1 technical regulations.
 - TR2:** these are specially prepared conventional cars in compliance with TR2 technical regulations.
 - OPEN:** conventional cars with more allowed changes that correspond to OPEN Technical specifications.
 - TR3:** automobiles- prototypes

These cars have undergone some major reconstructions they have newly created original constructions that comply with TR3 technical specifications.

- 3.2. Until the administrated check of the automobile by the technical commissar the participants have the right to change their current vehicle to another vehicle of the same category.
- 3.4. If during the technical commission the technical commissar detects that the vehicle does not correspond to the given category he has the right either to put the vehicle in the appropriate category or not to allow the team to participate in the race in which case the team's entry fee will not be refundable.

Chapter 4. Entries.

- 4.1. Anyone willing to participate in the NEZ CHAMPIONSHIP must send a filled out entry to the secretariat. The entry must contain following information:
 - Each participants Name, Surname, birth date, citizenship, address, phone number and driver's license number.
 - Description of the vehicle
 - Sample of the entry form is annex 2 to these regulations
 -
- 4.2. By signing the entry the participants agree to the official regulations of the NEZ CHAMPIONSHIP as well as to the organizing regulations of the Organizing regulations of Trophy raid NEZ event and regulations of the current race.
- 4.3. It is allowed to change the second driver until the administrative check. This change must be approved by responsible race personnel. If the team wants to exchange two of its members or the first driver than this change needs to be documented with written confirmation by the responsible race personnel, which becomes an inseparable part of team's entry and the team receives a copy of it.
- 4.4. The entry fee of the race shall not exceed 300 EUR
- 4.5. Organizer has the right to determine the amount and the time limit of the entry fees.
- 4.6. Entry fees are fully refunded to those participants, whose entries were not accepted. In case the race is cancelled or postponed for more than 24 hours.
- 4.7. Organizer refunds the entry fee partially (up to 50%) if the participant could not participate in the race due to approved force majeure conditions.
- 4.8. Entry fees are refunded during one month after the end of the race.
- 4.9. Organizer has the right to include extra fees in to the race regulations for car service, transport, hotels and public catering.
- 4.10 Entry fees do not cover the insurance policies; the participants are responsible that they have all the insurance policies needed from the beginning of the race till the race ends.

Chapter 5. Identification and advertisements.

- 5.1. Organizer provides each crew with two race emblems.
- 5.2 Race emblems (max size 43 cm width and 21.5 cm height) must contain status of the race the official name of the race and depending on the organizers choice either the name or the logo of main promoter.
 - 5.2.1 Front race emblem must be placed vertically on the front face of the car in the rectangle formed by these following lines:
 - Line going through the axis of the wheels
 - Two vertical lines, going through the inner sides of the front lamps
 - A horizontal line going through the lowest point of the front lampsIt is also possible to place the emblem on the front side of the hood.
The front emblem must be the first inscription to meet the eye except the cars manufacturer logo.
 - 5.2.2 Rear emblem also must be placed vertically on cars body or the rear window if it is not transparent.
 - 5.2.3 Emblems must not cover the cars registration number plates.
- 5.3. Racing numbers (size 50 cm width and 52 cm height, if it is impossible than 45×45) must be placed on the front doors of the vehicle.
- 5.4. If during the race an incorrect placement or absence of one of the race emblems or racing numbers is detected, a fine to the tune of 10% of the entry fee is charged. If during the race an incorrect placement or absence of both of the race emblems or racing numbers is detected, a fine to the tune of 20% of the entry fee is charged.
- 5.5. Surnames and names, (pseudonyms) of 1st and 2nd drivers and their national flags with minimal height of 30mm must be placed on either both front sides or doors of vehicle. If either one of these identification signs is missing fine to the tune of 10% of the entry fee is charged.
- 5.6. Participants have the right to position all kinds of advertisements on their cars as long as it:
 - does not contradict the law
 - does not contradict organizers indications
 - is not offensive
 - is not placed on racing numbers and emblems
 - is not on windscreen - does not affect visibility
- 5.7. Spots reserved by the organizer for obligatory advertisements are:
 - 9cm × 43cm bottom zone of the emblem
 - 14cm x 50cm zone on the top and bottom of the racing number
 - Two 10 cm high and 25 cm wide stripes on both sides of the top of the windscreen.
- 5.8. Place for organizers non obligatory advertisements, both back doors and sides of the vehicle.

5.9 Teams are responsible for placement of all the advertisements on their vehicles if a team is caught without the advertisements or has positioned those incorrect - 10% of the entry fee is charged, if the team is caught the second time for the same reason - 100% of the entry fee is charged.

5.10. If team refuses to place advertisements at all 100% of the entry fee is charged.

5.11. Advertisement placement scheme is handed out at the registrations.

Chapter 6. Point scores.

6.1. The winning crews of TR1, TR2, TR3 and OPEN categories are announced in 2021.

6.1.1. The crew or team who gains the most points during all the three series of the 2021 NEZ CHAMPIONSHIP is declared winner in its category. If some drivers have equal amount of points then they are judged by the last event. If these drivers again has the same amount of points the priority is given based on their first point match, if they again have the same amount of the points the places are shared.

6.2. According to the official calendar of 2021 NEZ CHAMPIONSHIP there are three series.

6.3. In each of the series points are allocated in each category separately. If some drivers have equal amount of points then they are judged by the last race. If these drivers again has the same amount of points the priority is given based on their first point match, if they again have the same amount of the points the places are shared.

6.4. Every participant receives points in the category that his vehicle was classified.

6.5. Crew has to participate at least in two of the three. series of the NEZ CHAMPIONSHIP to be listed in standings of CHAMPIONSHIP.

6.6 The points are calculated according to the table given in first annex of these regulations.

6.7. If the crew who has started in SS (special stage), has reached at least one WP (waypoint) and has left the track, not crossing the finish line or exceeds time limit of SS he get DNF (do not finished) and 0 points for this SS.

6.8. If the crew has not started in SS (special stage) result in this stage summary is calculated after all crews that has started in all or more stages.

6.9. If a participant was evacuated from SS by the another competitor still competing in section, it gets „0“ points for this stage.

6.10. If a participant was evacuated from SS by the another competitor, who do not compete in this section, by the organisers or bystanders it gets DNF (did not finished) and the team gets 0 points.

6.11. The participants, which are disqualified from the race, results are deleted from the competition result summary and all results are recalculated.

Chapter 7. Awards.

7.1. Crews that collect the most points are winners. They receive cups, medals, diplomas and prizes.

7.2. Cups, medals, diplomas are given to the first second and third crew.

7.3. Awards are funded by the organizer.

Chapter 8 . Organizers of 4x4 NEZ CHAMPIONSHIP 2021:

1. Lithuania 23-25.04.2021 – Kupiškiso trophy 2021

Mr. Vaidotas Paskevicius
+370 (612) 20 895
e-mail: vaidotaspas@gmail.com
www.4x4sport.lt

2. Latvia 23-25.07.2021- Signals EM Trophy 2021

Mr. Evalds Madernieks
e-mail: evaldsmadernieks@inbox.lv
www.trofi.lv

3. Estonia 15-17.10.2021 Sirgala MudEst 2021

Mr. Arto Künnapas , +372 509 0585
e-mail: mudestoffroad@gmail.com
<http://eal.4x4.ee/>

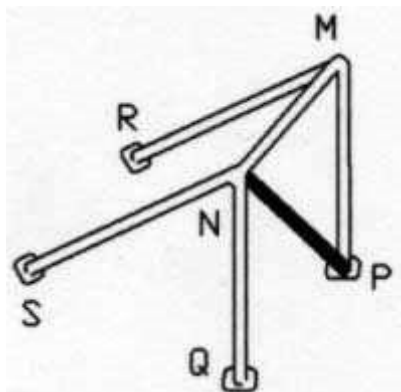

Material	Minimum tensile strength	Minimum dimensions (mm)	Use
Cold drawn seamless unalloyed carbon steel containing a maximum of 0.22% of carbon	350 N/mm ²	45(1,75'')x2,5 or 50(2,0'')x2,0	Main rollbar

Safety cage TR 2 with 3 passenger place and TR3

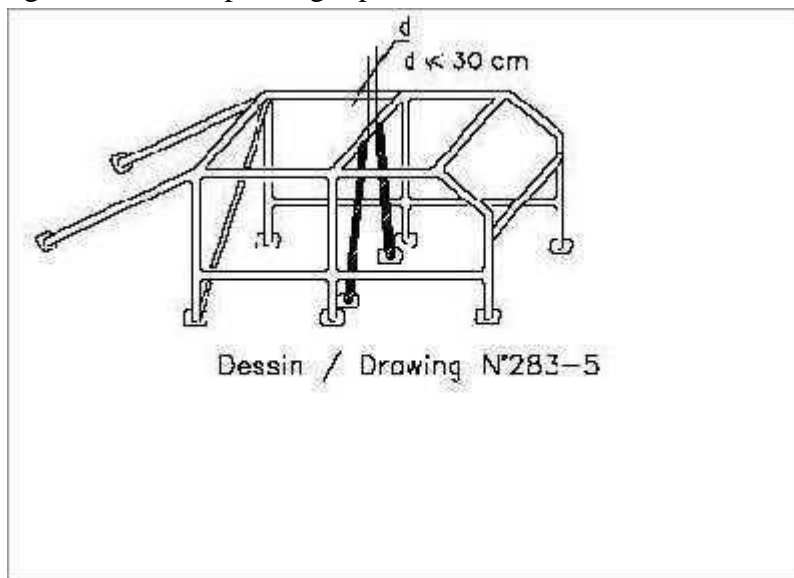

Принято и утверждено 4 декабря 2004 г. между странами и организаторами “Кубка Балтии 2005 -2008”. Пописи J. Lazdans – LV “Mazozoli”; M. Mumme – EE EAF, A. Sutkus – LT LVKA, V. Marozov – EE EORK; A. Myllyla – FIN Lapland 4Wheel drive Club.



4x4 NEZ CHAMPIONSHIP
TROPHY 2021

ENTRY FORM / PIETEIKUMA FORMA

CAR No. / STARTA Nr.		CLASS/ KATEGORIJA (TR1/TR2/TR3/OPEN)	
		Nepieciešama nr. Uzīme	
DATE / DATUMS			
ENTRANT NAME / PIETEICĒJS		PERSONAL CODE / PERSONAS KODS	
ADDRESS /ADRESE		TELEPHONES /TELEFONI	
		E-MAIL /E-PASTS	
I, entrant, here signed assure that all the information in the entry form is true / .Es, pieteicējs šeit parakstījis apliecinu, ka visa pieteikuma formā sniegtā informācija ir patiesa			
VEHICLE / AUTOMAŠĪNA			
MAKE MARKA		FIA technical passport TEHNISKĀS PASES Nr.	
MODEL MODELIS		YEAR OF MANUFACTURING IZLAIDUMA GADS	
		REGISTRATION Nr. REĢISTRĀCIJAS Nr.	

DRIVER /PILOTS	CO-DRIVER /STŪRMANIS
SURNAME /UZVĀRDS	SURNAME /UZVĀRDS
FIRST NAME /VĀRDS	FIRST NAME /VĀRDS
PERSONAL CODE / PERSONAS KODS	PERSONAL CODE / PERSONAS KODS
ADDRESS /Adrese	ADDRESS /Adrese
COUNTRY /VALSTS	COUNTRY /VALSTS
TELEPHONES /TELEFONI	TELEPHONES /TELEFONI
E-MAIL / E-PASTS	E-MAIL / E-PASTS
DRIVING LICENCE Nr VADĪTĀJA APLIECĪBAS Nr.	DRIVING LICENCE Nr VADĪTĀJA APLIECĪBAS Nr.
COMPETITOR LICENCE Nr/ LICENCES Nr	COMPETITOR LICENCE Nr/ LICENCES Nr
INSURANCE POLICY No /APDROŠINĀŠANAS POLISES Nr.	INSURANCE POLICY No /APDROŠINĀŠANAS POLISES Nr.
Insurance policy expires/ Apdrošināšanas polise derīga līdz	Insurance policy expires/ Apdrošināšanas polise derīga līdz
Visas personas, kas atrodas automašīnā apņemas pasākuma laikā ievērot Latvijā spēkā esošos CSN un uzņemas pilnu atbildību par savu darbību vai bezdarbību, kā arī atsakās no visām pretenzijām pret organizatoru un LAF oficiālajām personām. Apliecinu, ka pieteikumā minētā informācija ir pareiza.	
All persons who are in vehicle during the competition assure that they will follow Road traffic rules in force in territory of LATVIA and and takes all the risk for their action or inaction and renounce in advance all responsibility on the part of the organizers, its officials the Latvian Automobile Federation. I assure information included in entry form is true."	

SIGNATURE/ PARAKSTS _____

SIGNATURE/ PARAKSTS _____

2 CO-DRIVER /2 STŪRMANIS	3 CO-DRIVER /3 STŪRMANIS
SURNAME /UZVĀRDS	SURNAME /UZVĀRDS
FIRST NAME /VĀRDS	FIRST NAME /VĀRDS
PERSONAL CODE / PERSONAS KODS	PERSONAL CODE / PERSONAS KODS
ADDRESS /Adrese	ADDRESS /Adrese
COUNTRY /VALSTS	COUNTRY /VALSTS
TELEPHONES /TELEFONI	TELEPHONES /TELEFONI

E-MAIL / E-PASTS	E-MAIL / E-PASTS
DRIVING LICENCE Nr VADITĀJA APLIECĪBAS Nr.	DRIVING LICENCE Nr VADITĀJA APLIECĪBAS Nr.
COMPETITOR LICENCE Nr/ LICENCES Nr	COMPETITOR LICENCE Nr/ LICENCES Nr
INSURANCE POLICY No /APDROŠINĀŠANAS POLISES Nr.	INSURANCE POLICY No /APDROŠINĀŠANAS POLISES Nr.
Insurance policy expires/ Apdrošināšanas polise derīga līdz	Insurance policy expires/ Apdrošināšanas polise derīga līdz
<p>Visas personas, kas atrodas automašīnā aņņemas pasākuma laikā ievērot Latvijā spēkā esošos CSN un uzņemas pilnu atbildību par savu darbību vai bezdarbību. kā arī atsakās no visām pretenzijām pret organizatoru un LAF oficiālajām personām. Apliecinu, ka pieteikumā minētā informācija ir pareiza.</p>	
<p>All persons who are in vehicle during the competition assure that they will follow Road traffic rules in force in territory of LATVIA and and takes all the risk for their action or inaction and renounce in advance all responsibility on the part of the organizers, its officials the Latvian Automobile Federation. I assure information included in entry form is true."</p>	

SIGNATURE/ PARAKSTS _____

SIGNATURE/ PARAKSTS _____